

**Shower heat exchanger: reuse of energy from heated drinking water for CO<sub>2</sub> reduction**

Z. Deng et al.

# Shower heat exchanger: reuse of energy from heated drinking water for CO<sub>2</sub> reduction

Z. Deng<sup>1,2</sup>, S. Mol<sup>1</sup>, and J. P. van der Hoek<sup>1,2</sup>

<sup>1</sup>Waternet, Postbus 94370, 1090 GJ Amsterdam, the Netherlands

<sup>2</sup>Delft University of Technology, Department of Water Management, Stevinweg 1, 2628 CN Delft, the Netherlands

Received: 13 April 2015 – Accepted: 25 June 2015 – Published: 14 July 2015

Correspondence to: Z. Deng (z.deng@student.tudelft.nl)

Published by Copernicus Publications on behalf of the Delft University of Technology.

This discussion paper is/has been under review for the journal Drinking Water Engineering and Science (DWES). Please refer to the corresponding final paper in DWES if available.

Title Page

Abstract

Introduction

Conclusions

References

Tables

Figures



Back

Close

Full Screen / Esc

Printer-friendly Version

Interactive Discussion

## Abstract

The heating of drinking water in households contributes for a significant amount to the emission of greenhouse gases. As a water utility aiming to operate climate neutral by 2020, Waternet needs to reduce its CO<sub>2</sub> emission by 53 kton yr<sup>-1</sup>. To contribute to this ambition, a pilot project was carried out in Uilenstede, Amstelveen, the Netherlands, to recover the shower heat energy with a shower heat exchanger from Dutch Solar Systems. An experimental set up was built in the Waternet laboratory to compare field conditions and lab conditions. The energy recovery efficiency observed in the lab was 61–64 % under winter conditions and 58–62 % under summer conditions, while the energy recovery efficiency observed in Uilenstede was 57 % in December 2014. Based on the observations, 4 % of the total energy consumption of households in Amsterdam (electricity and gas) can be recovered with a shower heat exchanger installed in all households in Amsterdam, which also means a 54 kton yr<sup>-1</sup> CO<sub>2</sub> emission reduction.

## 1 Introduction

In the Netherlands, the domestic drinking water consumption is 118.9 L per capita per day (Van Thiel, 2014). Drinking water used for showering, bathing, dish washing by machine and cloth washing by machine is heated directly and contributes for 59 % to the domestic drinking water consumption. Drinking water is also warmed up by room temperature during non-consumption periods (i.e. stagnant water in the pipes inside the building, in the toilet sink) substantial amount of thermal energy added to the drinking water leaves the house after the water has been used. According to Hofman et al. (2011) this heated drinking water leaves the house at an average temperature of 27 °C. The heated drinking water contributes for 40 % to the heat loss of a modern house, which is equivalent to 450 kg CO<sub>2</sub> yr<sup>-1</sup> (van der Hoek, 2012a).

Waternet, the water utility of Amsterdam and surroundings, has the ambition to operate climate neutral in 2020 (Van der Hoek, 2012a). This ambition is driven by the policy

## DWESD

8, 119–141, 2015

### Shower heat exchanger: reuse of energy from heated drinking water for CO<sub>2</sub> reduction

Z. Deng et al.

Title Page

Abstract

Introduction

Conclusions

References

Tables

Figures



Back

Close

Full Screen / Esc

Printer-friendly Version

Interactive Discussion



## Shower heat exchanger: reuse of energy from heated drinking water for CO<sub>2</sub> reduction

Z. Deng et al.

Title Page

Abstract

Introduction

Conclusions

References

Tables

Figures



Back

Close

Full Screen / Esc

Printer-friendly Version

Interactive Discussion

targets of the City of Amsterdam. The City of Amsterdam aims at a climate neutral municipal organization in 2015, 40% reduction of greenhouse gas emissions in 2025 compared to 1990, and 75% reduction of greenhouse gas emissions in 2040 (City of Amsterdam, 2009). For Waternet, a climate neutral operation necessitates a reduction of greenhouse gas emissions of 53 kton CO<sub>2</sub> yr<sup>-1</sup> (Van der Hoek, 2012b). For the City of Amsterdam, a 75% reduction in greenhouse gas emissions implies a reduction of 3100 kton CO<sub>2</sub> yr<sup>-1</sup> (City of Amsterdam, 2009).

The importance of reducing greenhouse gas emissions is even more stressed when the IPCC's (Intergovernmental Panel on Climate Change) Fifth Assessment Report is taken into account (IPCC, 2013). One of the conclusions is that continued emissions of greenhouse gases will cause further warming and changes in all components of the climate system. Limiting climate change will require substantial and sustained reductions of greenhouse gas emissions.

For Waternet, first calculations reveal that 148 kton yr<sup>-1</sup> greenhouse gas emission reduction can be reached by energy recovery from the water cycle in and around Amsterdam, of which 72 kton yr<sup>-1</sup> is the heat from wastewater (van der Hoek, 2012a). Thermal energy recovery from the heated drinking water is a promising way to reach climate neutrality by 2020.

Taking into account the three main components for heat recovery (a heat source, a heat exchanger and a consumption point), suitable conditions have to be found to optimize its feasibility. Compared to mixed heated water from households, shower water seems more attractive due to the facts that it has a high volume (about 50 L day<sup>-1</sup>) and a high temperature (about 35 °C). Furthermore, the consumption and recovery are simultaneous in time and location, thus no storage system is required and no extra losses take place during a short distance of heat delivery.

A shower heat exchanger is specially designed for recovering thermal energy from used shower water. It can be installed under a shower tray to transfer the heat from shower water to cold drinking water. As the drinking water has been preheated, total energy consumption to heat the water can be reduced.

The company Dutch Solar Systems (DSS) claims their shower heat exchanger has an energy recovery efficiency of 47 % (horizontal version) to 62 % (vertical version), based on a given flow rate (Dutch Solar Systems, 2015). This means that about half of the heat in the shower water can be recovered to reduce the energy (i.e. electricity, gas) consumption.

To validate the energy recovery efficiency of the DSS shower heat exchanger in practice, a pilot project was constructed in Campus Uilenstede, a housing estate for students in Amstelveen near Amsterdam, in September 2014. 100 Shower heat exchangers were installed in the single-student houses. 10 apartments were monitored: 2 reference apartments without shower heat exchanger, 2 apartments with the horizontal version, and 6 with the vertical version. For comparison, an experimental set up was built in the Waternet laboratory with the same configuration as in the student houses (vertical shower heat exchanger).

In addition to the energy recovery efficiency, the sustainability of the heat exchangers' efficiency was also studied regarding four main factors:

- flow rate,
- duration of the shower,
- time interval between two showers,
- shower temperature and incoming water temperature.

The annual energy saving potential, and the economic payback time of the shower heat exchangers were calculated, and compared with the DSS documents and former estimations.

## DWESD

8, 119–141, 2015

### Shower heat exchanger: reuse of energy from heated drinking water for CO<sub>2</sub> reduction

Z. Deng et al.

Title Page

Abstract

Introduction

Conclusions

References

Tables

Figures



Back

Close

Full Screen / Esc

Printer-friendly Version

Interactive Discussion



## 2 Materials and methods

### 2.1 Installations and configurations

Considering the cost and efficiency, the DSS shower heat exchanger was chosen in this the project.

#### 2.1.1 Project Uilenstede

In Uilenstede Amstelveen, 10 rooms were fitted with a shower heat exchanger and then monitored with two flow meters and two temperature sensors. The locations of these rooms are shown in Fig. 1. The configuration of the setup in each room is illustrated in Fig. 2.

In Fig. 2, the dark blue line represents the cold water flow, which partially goes to the taps (in bathroom and kitchen) and partially goes to the heat exchanger and heater. Its flow and temperature are measured by the two sensors – “F total” and “T cold”. The light blue line represents the preheated water, which feeds both the thermostatic valve and the heater. Two sensors, “T preheated” and “F shower”, are measuring its temperature and flow. The red line represents the water heated by the heater and feeds to all hot water-consuming points.

These four sensors starts to collect data whenever there is water consumption in the room, thus all showers taken were recorded and then transported to Waternet database. The shower water near the drain was measured manually.

Due to technical problems with the monitoring system, only data from one room (B0218, vertical WTW-unit) was valid in this phase.

#### 2.1.2 Laboratory

The laboratory setup was built to mimic the performance of the shower heat exchanger in Uilenstede, but in a more controlled environment. The configuration of the system

## Shower heat exchanger: reuse of energy from heated drinking water for CO<sub>2</sub> reduction

Z. Deng et al.

[Title Page](#)

[Abstract](#)

[Introduction](#)

[Conclusions](#)

[References](#)

[Tables](#)

[Figures](#)



[Back](#)

[Close](#)

[Full Screen / Esc](#)

[Printer-friendly Version](#)

[Interactive Discussion](#)





## 2.3 Analysis methods

The energy and efficiency calculations are based on the standard method (NEN 7120+C2:2012, 2012).

$$\begin{aligned} Q_{\text{recovered}} &= \sum \{q_{\text{cold}} \times \rho(T_{\text{cold}}) \times [h(T_{\text{preheated}}) - h(T_{\text{cold}})] \times dt\} \\ Q_{\text{waste}} &= \sum \{q_{\text{shower}} \times \rho(T_{\text{shower}}) \times [h(T_{\text{shower}}) - h(T_{\text{cold}})] \times dt\} \\ \eta_{\text{recover}} &= \frac{Q_{\text{recovered}}}{Q_{\text{waste}}} \end{aligned} \quad (1)$$

where  $Q_{\text{waste}}$  is the total energy in used shower water in [kJ];  $Q_{\text{recovered}}$  is the energy recovered by the shower heat exchanger in [kJ];  $q_{\text{cold}}$  is the drinking water flow rate through the shower heat exchanger in [ $\text{m}^3 \text{s}^{-1}$ ];  $q_{\text{shower}}$  is the shower water flow rate (should be the same as  $q_{\text{cold}}$  in our laboratory case) through the shower heat exchanger in [ $\text{m}^3 \text{s}^{-1}$ ].  $\rho(T)$  and  $h(T)$  are the specific density and enthalpy of the water, as functions of the temperature according to:

$$\begin{aligned} \rho(T) &= 999.9649 + 0.0264672 \times T - 0.0061549 \times T^2 + 1.775 \times 10^{-5} \times T^3 \quad \text{in } [\text{kJ kg}^{-1}]; \\ h(T) &= 0.167853 + 4.18587 \times T - 0.000146789 \times T^2 + 9.38153 \times 10^{-7} \times T^3 \\ &\quad + 8.36764 \times 10^{-9} \times T^4 \quad \text{in } [\text{kJ kg}^{-1}]. \end{aligned}$$

$\eta_{\text{recover}}$  is the energy recovery efficiency [%].

## 2.4 Greenhouse gas emissions

With the energy saved per shower calculated by the Eq. (1), greenhouse gas emissions have been calculated with the factors and other parameters (from Waternet) in Table 3.

### Shower heat exchanger: reuse of energy from heated drinking water for CO<sub>2</sub> reduction

Z. Deng et al.

Title Page

Abstract

Introduction

Conclusions

References

Tables

Figures

◀

▶

◀

▶

Back

Close

Full Screen / Esc

Printer-friendly Version

Interactive Discussion



## 3 Results and discussion

### 3.1 Energy recovery efficiency

With different types of heaters and fluctuations in drinking water temperature, there might be some minor variations in the time needed to stabilize the system. In general, it takes about 90 seconds to reach 90 % (summer) to 99 % (winter) of the final shower water temperature and preheated water temperature. In the Dutch Standard Method (NEN 7120+C2:2012), the calculation of energy recovery efficiency starts after the system becomes stable. But in this way, the energy saved during the warm-up period is excluded. The data in this study is collected from the beginning of the shower, therefore the whole shower period is included. This influence describes the performance of the shower heat exchanger in a more realistic manner.

#### 3.1.1 Impact of flow rates, shower durations, water temperature differences and shower intervals

In winter conditions (Fig. 5, left), the cold water temperature in practice is around 11 °C (9–10 °C in the experiment). The shower water temperature is supposed to be around 38 °C when it drains. The flow rate is 5.4 L min<sup>-1</sup> for the first 3 tests (18 showers) and 6.5 L min<sup>-1</sup> for the following 3 tests (another 18 showers). The average energy recovery efficiency of a 5.4 L min<sup>-1</sup> flow rate is in the range of 64 and 64.5 %. When showering with a higher flow rate (6.5 L min<sup>-1</sup>), the average energy recovery efficiency is around 61.5–62 %. The efficiency gradually increases with the shower durations, but within 0.5 %. Which means that the efficiency of the shower heat exchanger is roughly stable against shower duration in winter.

In summer conditions (Fig. 5, right), the cold water temperature in practice can exceed 20 °C. It is more likely that people take a shower with a lower water temperature than in winter, and in this study, 33 °C was chosen for this reason as a normal summer shower temperature. A flow rate of 5.2 L min<sup>-1</sup> is used for the first three showers

DWESD

8, 119–141, 2015

Shower heat exchanger: reuse of energy from heated drinking water for CO<sub>2</sub> reduction

Z. Deng et al.

Title Page

Abstract

Introduction

Conclusions

References

Tables

Figures

⏪

⏩

◀

▶

Back

Close

Full Screen / Esc

Printer-friendly Version

Interactive Discussion





## Shower heat exchanger: reuse of energy from heated drinking water for CO<sub>2</sub> reduction

Z. Deng et al.

Title Page

Abstract

Introduction

Conclusions

References

Tables

Figures



Back

Close

Full Screen / Esc

Printer-friendly Version

Interactive Discussion



which results in an energy recovery efficiency of 61–62%. A flow rate of 6.8 L min<sup>-1</sup> is used for the last three showers which results in an energy recovery efficiency of 57–58%. Considering the shower duration, at flow rate of 5.2 L min<sup>-1</sup>, the average efficiency for 8 min showers is 61.0%, and rises to 62.4% for 30 min showers, thus 1.4% increase is achieved. In winter conditions, the increase is only 0.5%. When showering at 6.8 L min<sup>-1</sup>, the same phenomenon is observed: an extension from 8 min showers to 30 min showers in summer conditions results in an efficiency increase of 1% while in winter an increase of only 0.5% is observed. Temperature differences between cold drinking water and shower water are smaller in summer conditions, which result in a slightly lower (overall) efficiency. Besides, shower duration plays a more recognizable role under these summer conditions.

Figure 6 shows six consecutive showers with increasing time intervals between the showers (10, 20, 30, 60 and 120 min), both for a flow rate of 5.4 and 6.5 L min<sup>-1</sup>. The time intervals between the showers affect the efficiencies, but only for shorter showers (< 15 min). This effect is negligible for long showers exceeding 20 min.

### 3.1.2 Project Uilenstede

Records of four showers were found in Room B0218, and an average energy recovery efficiency of 57% was calculated (with a shower temperature of about 34.5°C near the drain, a cold water temperature around 12.5°C, and a flow rate about 6.4 L min<sup>-1</sup> measured both by sensors and manually).

In the student houses, the shower energy recovery efficiency is lower. The cause is likely a combination of the tap water temperature being higher than the average drinking water temperature (14.5°C in September and 12.5°C in December 2014), a higher flow rate than the first comfort class (5.8 L min<sup>-1</sup>), and a longer distance from the drain to the exchanger's inlet.

## 3.2 Energy savings and CO<sub>2</sub> reduction

The average electricity and gas consumption in households is about 1800 kWh yr<sup>-1</sup> and 1600 Nm<sup>3</sup> yr<sup>-1</sup> in Amsterdam (in 2012), the total energy consumption equals 1770 kton CO<sub>2</sub> emission (Table 3).

Assuming people take a 10 min shower each day with a water saving shower valve (about 5 L min<sup>-1</sup>), 0.4 kWh (in summer) and 1.1 kWh (in winter) per shower can be saved by a shower heat exchanger (based on lab results). With 412 000 houses and a population density of 2 per dwelling in Amsterdam, the energy that can be recovered is around 900 000 kWh day<sup>-1</sup> in winter and 300 000 kWh day<sup>-1</sup> in summer. The energy recovered in one year is approximate 260 million kWh (122 days are counted as summer with average drinking water temperature above 20 °C; 243 days as winter). This is 4.0 % of the total households electricity and gas consumption, which equals 6540 million kWh (Table 5).

In the Netherlands, shower water is mostly heated by gas. With a shower heat exchanger in every house in Amsterdam, a 4.5 % reduction in gas consumption can be achieved per year, which is equivalent to saving about 30 million Nm<sup>3</sup> gases, or a reduction of 54 kton CO<sub>2</sub>. Regarding the reduction requirement of Waternet of 53 kton yr<sup>-1</sup> (van der Hoek, 2012b), this would be a significant achievement.

The energy saved compared to total electricity consumption is 35 % in this study (Table 5), which is 15 % higher than the estimation by the Ministry of Housing, Physical Planning and Environment and TAUW in 2010 (Ministry of Housing, Physical Planning and Environment and TAUW, 2010). In this report the energy that can be recovered from shower water was estimated to be 20 % of the total electricity consumption in households.

## 3.3 Payback period

A shower heat exchanger costs about EUR 400 and the installation about EUR 100–600, which brings the total costs to about EUR 500–1000. With an average gas

## Shower heat exchanger: reuse of energy from heated drinking water for CO<sub>2</sub> reduction

Z. Deng et al.

Title Page

Abstract

Introduction

Conclusions

References

Tables

Figures



Back

Close

Full Screen / Esc

Printer-friendly Version

Interactive Discussion



## Shower heat exchanger: reuse of energy from heated drinking water for CO<sub>2</sub> reduction

Z. Deng et al.

Title Page

Abstract

Introduction

Conclusions

References

Tables

Figures

◀

▶

◀

▶

Back

Close

Full Screen / Esc

Printer-friendly Version

Interactive Discussion

price of EUR 0.55 per Nm<sup>3</sup>, and the annual gases saving (about 71.7 Nm<sup>3</sup>) in a 2-persons household, the payback period is around 13–25 years. The payback period might be longer for single occupancy houses and shorter for houses with more residents. Concerning the houses using electricity for water heating (electricity price 5 EUR 0.23 kWh<sup>-1</sup>), the payback period can be as short as 4–7 years. The estimation of payback period is close to the estimation (4–25 years) found by Mol (2013).

## 4 Conclusions

The energy recovery efficiency observed in this study (58–64 % observed in the lab and 57 % observed in Uilenstede) is quite close to the claimed efficiency (56–62.7 % for vertical shower heat exchanger). The performance of the shower heat exchanger is relatively stable regarding different shower durations, shower intervals and seasonal impacts, while the flow rate of the shower was shown to have a more significant influence: a lower flow rate resulted in a higher energy recovery efficiency thus combining shower heat exchangers with water saving shower valves is recommended.

15 With a shower heat exchanger, the energy recovered by 412 000 households in Amsterdam is about 260 million kWh yr<sup>-1</sup>, which equals an avoided greenhouse gas emission of 54 kton CO<sub>2</sub>. The potential of shower heat exchangers is promising, and they could provide a large contribution to the CO<sub>2</sub> reduction target of Waternet in 2020.

20 The average payback period in a 2-person household that uses gas for heating shower water is about 13–25 years compared to about 4–7 years for the same house using electricity for heating water.

**The Supplement related to this article is available online at doi:10.5194/dwesd-8-119-2015-supplement.**

## References

- City of Amsterdam: Amsterdam: a Different Energy – 2040 Energy Strategy, Report City of Amsterdam, Klimaatbureau, Amsterdam, the Netherlands, 2009.
- Dutch Solar Systems: DSS shower drain water heat recovery unit, Enschede, the Netherlands, available at: [http://www.dutchsolarsystems.com/douche\\_wtw/downloads/4029152-folder%20DSS-douchepijp-ENGELS-LR.pdf](http://www.dutchsolarsystems.com/douche_wtw/downloads/4029152-folder%20DSS-douchepijp-ENGELS-LR.pdf), last access: 03 March 2015.
- Hofman, J., Hofman-Caris, R., Nederlof, M., Frins, J., and Van Loosdrecht, M.: Water and energy as inseparable twins for sustainable solutions, *Water Sci. Technol.*, 63, 88–92, 2011.
- IPCC: Summary for policymakers, in: *Climate Change 2013: The Physical Science Basis. Contribution of Working Group I to the Fifth Assessment Report of the Intergovernmental Panel on Climate Change*, edited by: Stocker, T. F., Qin, D., Plattner, G. K., Tignor, M., Allen, S. K., Boschung, J., Nauels, A., Xia, Y., Bex, V., and Midgley, P. M., Cambridge University Press, Cambridge, UK and New York, NY, USA, 4–29, [http://www.ipcc.ch/pdf/assessment-report/ar5/wg1/WG1AR5\\_SPM\\_FINAL.pdf](http://www.ipcc.ch/pdf/assessment-report/ar5/wg1/WG1AR5_SPM_FINAL.pdf), 2013.
- Ministry of Housing, Physical Planning and Environment and TAUW: Energie uit afvalwater – de ongekende potentie van thermische energie (Energy from wastewater – the unprecedented potency of thermal energy). Report Ministry VROM and TAUW, available at: [http://www.tauw.nl/fileadmin/downloads/expertise/Brochure\\_Energie\\_uit\\_afvalwater\\_\\_Rijksoverheid\\_\\_Tauw.pdf](http://www.tauw.nl/fileadmin/downloads/expertise/Brochure_Energie_uit_afvalwater__Rijksoverheid__Tauw.pdf) (last access: 27 December 2014), 2010.
- Mol, S.: Evaluation of shower heat exchanger as a means for CO<sub>2</sub> reduction in the water cycle, Report Waternet, Amsterdam, the Netherlands, 2013.
- NEN 7120+C2:2012: Energieprestatie van gebouwen – Bepalingsmethode (Dutch Standard “Energy performance of buildings”), the Netherlands Standardisation Institute, Delft, the Netherlands, 2012.
- van der Hoek, J. P.: Climate change mitigation by recovery of energy from the water cycle: a new challenge for water management, *Water Sci. Technol.*, 65, 135–141, 2012a.
- Van der Hoek, J. P.: Towards a climate neutral water cycle, *Journal of Water and Climate Change*, 3, 163–170, 2012b.
- Van Thiel, L.: Watergebruik Thuis 2013 (Water Use at Home 2013), Report G5707 TNS Nipo/Vewin, 17 February 2014, Amsterdam, the Netherlands, 2014.

## DWESD

8, 119–141, 2015

### Shower heat exchanger: reuse of energy from heated drinking water for CO<sub>2</sub> reduction

Z. Deng et al.

Title Page

Abstract

Introduction

Conclusions

References

Tables

Figures



Back

Close

Full Screen / Esc

Printer-friendly Version

Interactive Discussion



## Shower heat exchanger: reuse of energy from heated drinking water for CO<sub>2</sub> reduction

Z. Deng et al.

Title Page

Abstract

Introduction

Conclusions

References

Tables

Figures



Back

Close

Full Screen / Esc

Printer-friendly Version

Interactive Discussion



**Table 1.** Summary of experiments.

	EXP1	EXP2
Interval between showers (min)	10; 20; 30; 60; 120	15
Number of tests	6	2
Shower durations (min)	30	30
Flow rates (L min <sup>-1</sup> )	5.4; 6.5	5.2; 6.8
Shower temperature (°C)*	38	33
Cold water temperature (°C)	10	20

\* Shower temperature is the temperature measured near the drain.

## Shower heat exchanger: reuse of energy from heated drinking water for CO<sub>2</sub> reduction

Z. Deng et al.

[Title Page](#)

[Abstract](#)

[Introduction](#)

[Conclusions](#)

[References](#)

[Tables](#)

[Figures](#)



[Back](#)

[Close](#)

[Full Screen / Esc](#)

[Printer-friendly Version](#)

[Interactive Discussion](#)

**Table 2.** Shower schedule per test.

EXP 1		EXP 2	
Time (CEST)	Showers	Time (CEST)	Showers
09:00–09:30	1	09:00–09:30	1
09:40–10:10	2		
10:30–11:00	3	09:45–10:15	2
11:30–12:00	4		
13:00–13:30	5	10:30–11:00	3
15:30–16:00	6		

## Shower heat exchanger: reuse of energy from heated drinking water for CO<sub>2</sub> reduction

Z. Deng et al.

[Title Page](#)

[Abstract](#)

[Introduction](#)

[Conclusions](#)

[References](#)

[Tables](#)

[Figures](#)

[⏪](#)

[⏩](#)

[◀](#)

[▶](#)

[Back](#)

[Close](#)

[Full Screen / Esc](#)

[Printer-friendly Version](#)

[Interactive Discussion](#)

**Table 3.** Conversion factors and parameters used for CO<sub>2</sub>-eq calculation.

Parameter	Value	Unit
CO <sub>2</sub> -eq conversion factor 1	$1.63 \times 10^{-10}$	kton CO <sub>2</sub> -eq kJ <sup>-1</sup> electricity
CO <sub>2</sub> -eq conversion factor 2	$1.8 \times 10^{-6}$	kton CO <sub>2</sub> -eq Nm <sup>-3</sup> gas
Population in Amsterdam	800 000	–
Number of houses in Amsterdam	412 000	–
Natural gas consumption per household	1600	Nm <sup>3</sup>
Electricity consumption per household	1800	kWh
Nm <sup>3</sup> gas conversion to kWh	$8.76 \times 10^{-3}$	kWh Nm <sup>-3</sup>

## Shower heat exchanger: reuse of energy from heated drinking water for CO<sub>2</sub> reduction

Z. Deng et al.

[Title Page](#)

[Abstract](#)

[Introduction](#)

[Conclusions](#)

[References](#)

[Tables](#)

[Figures](#)

[⏪](#)

[⏩](#)

[◀](#)

[▶](#)

[Back](#)

[Close](#)

[Full Screen / Esc](#)

[Printer-friendly Version](#)

[Interactive Discussion](#)



**Table 4.** Comparison of energy efficiencies.

	DSS*	Lab		Uilenstede		
		Winter	Summer			
Shower temperature °C	40	38	33		34.5	
Cold water temperature °C	10	9–10	19–20		12.5	
Flow rate (L min <sup>-1</sup> )	5.8	5.4	6.5	5.2	6.8	6.4
Efficiency (%)	62.7	64	61	62	58	57

\* Dutch Solar Systems (2015)



## Shower heat exchanger: reuse of energy from heated drinking water for CO<sub>2</sub> reduction

Z. Deng et al.

[Title Page](#)

[Abstract](#)

[Introduction](#)

[Conclusions](#)

[References](#)

[Tables](#)

[Figures](#)



[Back](#)

[Close](#)

[Full Screen / Esc](#)

[Printer-friendly Version](#)

[Interactive Discussion](#)



**Table 5.** Estimation of energy recovery and CO<sub>2</sub> emission reduction.

Annual energy saved by shower heat exchanger	kWh	260 000 000
Electricity consumed in households	kWh	740 000 000
Gas consumed in households	kWh	5 800 000 000
Annual total consumption	kWh	6 540 000 000
Saving compared to electricity	%	35.0
Saving compared to gas	%	4.5
Saving compared to total energy	%	4.0
CO <sub>2</sub> reduction	kton	54

# DWESD

8, 119–141, 2015

## Shower heat exchanger: reuse of energy from heated drinking water for CO<sub>2</sub> reduction

Z. Deng et al.

- B0016 No WTW-units
- B0017 Horizontal WTW-units
- B0117 Vertical WTW-units
- B0217 Vertical WTW-units
- B0317 Vertical WTW-units
- B0018 Horizontal WTW-units
- B0118 Vertical WTW-units
- B0218 Vertical WTW-units
- B0318 Vertical WTW-units
- B0019 No WTW-units

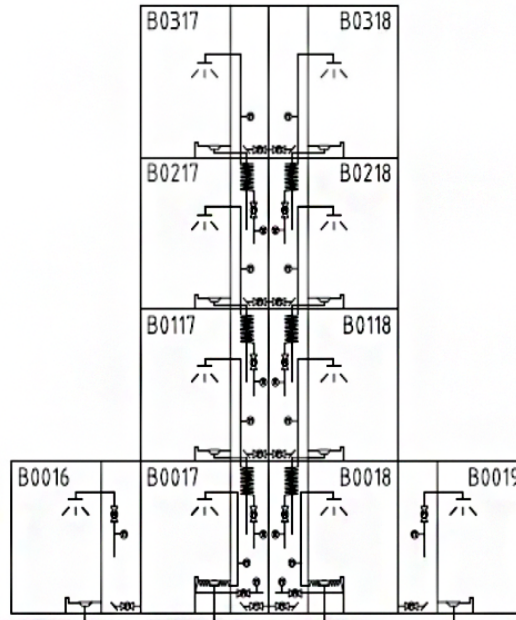

**Figure 1.** Student houses monitored.

Title Page	
Abstract	Introduction
Conclusions	References
Tables	Figures
◀	▶
◀	▶
Back	Close
Full Screen / Esc	
Printer-friendly Version	
Interactive Discussion	



## Shower heat exchanger: reuse of energy from heated drinking water for CO<sub>2</sub> reduction

Z. Deng et al.

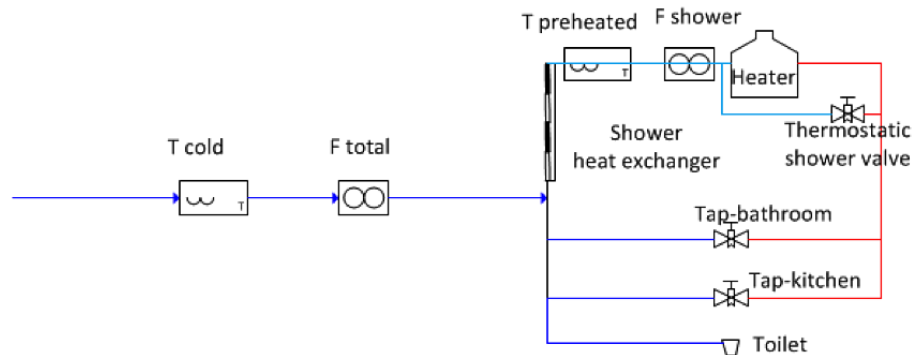

**Figure 2.** Project set up diagram ( $F$  = flow meter,  $T$  = temperature sensor).

[Title Page](#)

[Abstract](#)

[Introduction](#)

[Conclusions](#)

[References](#)

[Tables](#)

[Figures](#)

[◀](#)

[▶](#)

[◀](#)

[▶](#)

[Back](#)

[Close](#)

[Full Screen / Esc](#)

[Printer-friendly Version](#)

[Interactive Discussion](#)

# DWESD

8, 119–141, 2015

## Shower heat exchanger: reuse of energy from heated drinking water for CO<sub>2</sub> reduction

Z. Deng et al.



**Figure 3.** Experimental setup of the laboratory configuration.

[Title Page](#)

[Abstract](#)

[Introduction](#)

[Conclusions](#)

[References](#)

[Tables](#)

[Figures](#)

[◀](#)

[▶](#)

[◀](#)

[▶](#)

[Back](#)

[Close](#)

[Full Screen / Esc](#)

[Printer-friendly Version](#)

[Interactive Discussion](#)



## Shower heat exchanger: reuse of energy from heated drinking water for CO<sub>2</sub> reduction

Z. Deng et al.

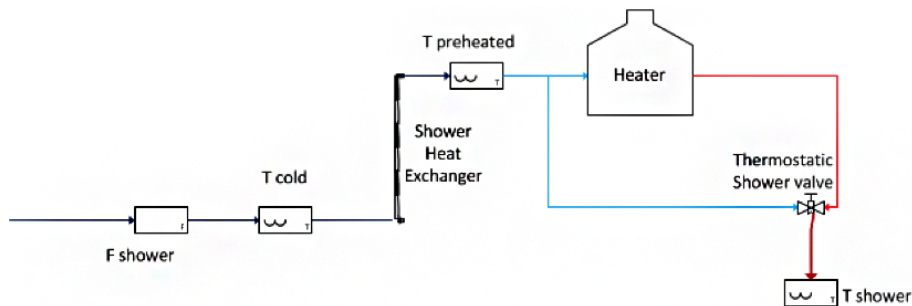

**Figure 4.** Flow diagram of the laboratory configuration ( $F$  = flow meter,  $T$  = temperature sensor).

[Title Page](#)

[Abstract](#)

[Introduction](#)

[Conclusions](#)

[References](#)

[Tables](#)

[Figures](#)

[◀](#)

[▶](#)

[◀](#)

[▶](#)

[Back](#)

[Close](#)

[Full Screen / Esc](#)

[Printer-friendly Version](#)

[Interactive Discussion](#)

## Shower heat exchanger: reuse of energy from heated drinking water for CO<sub>2</sub> reduction

Z. Deng et al.

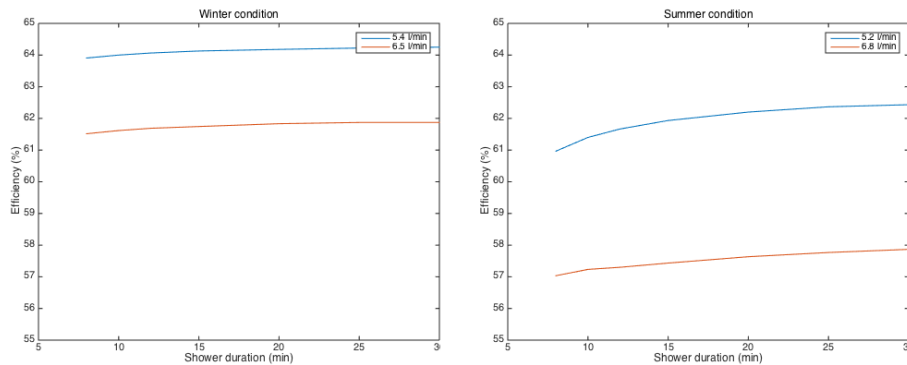

**Figure 5.** Energy recovery efficiencies versus impact parameters.

[Title Page](#)

[Abstract](#)

[Introduction](#)

[Conclusions](#)

[References](#)

[Tables](#)

[Figures](#)



[Back](#)

[Close](#)

[Full Screen / Esc](#)

[Printer-friendly Version](#)

[Interactive Discussion](#)



## Shower heat exchanger: reuse of energy from heated drinking water for CO<sub>2</sub> reduction

Z. Deng et al.

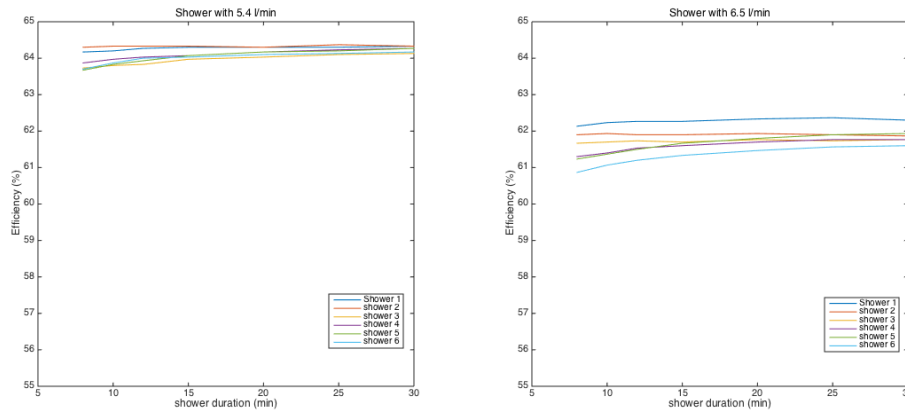

**Figure 6.** Energy recovery efficiency of each shower (average of 3 tests) in EXP 1.

Title Page

Abstract	Introduction
Conclusions	References
Tables	Figures

◀	▶
◀	▶
Back	Close

Full Screen / Esc

Printer-friendly Version

Interactive Discussion