

Interactive comment on “Accumulation and modeling of particles in drinking water pipe fittings” by K. Neilands et al.

Anonymous Referee #1

Received and published: 10 May 2012

Reply to 1nd referee by K.Neilands, M.Bernats and J. Rubulis

We thank the referee for the comments.

1. Does the paper address relevant scientific questions within the scope of DWES?

Definitely.

2. Does the paper present novel concepts, ideas, tools, or data? Yes.

3. Are substantial conclusions reached? Not entirely.

4. Are the scientific methods and assumptions valid and clearly outlined? Not entirely.

5. Are the results sufficient to support the interpretations and conclusions? Yes

6. Is the description of experiments and calculations sufficiently complete and precise

to allow their reproduction by fellow scientists (traceability of results)? Good description

of the relevant fieldwork but the data analysis method could be made clearer. 7. Do the

authors give proper credit to related work and clearly indicate their own

new/original contribution? This has been done very well.

8. Does the title clearly reflect the contents of the paper? A good title.

9. Does the abstract provide a concise and complete summary? Yes.

10. Is the overall presentation well structured and clear? Sometimes confusing. 11. Is the

language fluent and precise? It is sometimes confusing and would benefit

from proofreading by someone with a strong grasp of English. 12. Are mathematical formulae, symbols, abbreviations, and units correctly defined

and used? There are a number of errors and inconsistencies (see below).

13. Should any parts of the paper (text, formulae, figures, tables) be clarified, reduced, combined, or eliminated? See below.

14. Are the number and quality of references appropriate? Yes. 15. Is the amount and quality of supplementary material appropriate? The paper would

benefit from 1-2 additional examples of how J values are calculated.

ANSWER: Examples are attached in a different file

Key points:

- An interesting and important issue has been investigated
- The failing of previous discolouration studies to explain how much material accumulates in fittings is well presented. This 'motivation section' includes many relevant references.
- The explanation of the PODDS model (concepts, assumptions, formulas, variables, units) could be expressed more concisely and more consistently.

ANSWER: Thanks for the comment, will be done

Explanation of PODDS is mostly taken from publications: Boxall, J. B. and Saul, A. J.: Modeling discoloration in potable water distribution systems, 2005. and Ryan, G., Mathes, M., Haylock, G., Jayaratne, A., Wu, J., Noui-Mehidi, N., Grainger, C., and Nguyen, B. V.: Particles in Water Distribution Systems

- The definition of J values and the methods for calculating J values and mobilised material masses are not clear. I don't presently understand whether the turbidity curves can be repeatedly analysed in an automatable way to produce J values. A flow chart could help here.

ANSWER: Flow chart is attached to answers. I integrated NTU units from turbidity curve and multiplied with NTU-dry mass correlation $TSS=77.3 \text{ mg/l}$ (Boxall 2003)

In principle, calculation of the J value is possible with a simple algorithm in MS Excel by using data from turbidity curve and specific length flushed pipe, e.g. sections between fittings

- Tests for correlations and for measures of fit need to be explained and quantified if possible.
- The grammar, spelling and units used in the paper need thoroughly checking.

Ideas for improvement:

As someone with an interest in this research I am personally interested in the following questions:

- What proportion of anomalous turbidity spikes can be associated with the locations of pipe fittings?

ANSWER: Our experience showed that in more than 70 % cases turbidity pikes are associated with location of pipe fittings. At the moment we suggest to calculate average coefficient, which proportion is depending of average turbidity during flushing and maximal reached value, which is various.

- Can the above figure be broken down by fitting type?

ANSWER: No, while the most often found fitting is T-piece.

Specific comments:

140:5: 0.29kg of material should be quantified w.r.t. the total amount mobilised. ANSWER: Agree

140:21: 'Ryan' incorrectly spelt ANSWER: Agree

140:24: What does 'ud' mean?

ANSWER: Rayan et al., 2008 from experiments in pipe loop defined threshold 0.07 m s^{-1} as a velocity at which particles will deposit and named it as u_d .

141:4: 'precipitated'? Discussing particle deposition, which is unlikely to be solely due to precipitation.

ANSWER: We agree, while from 140:25-141:5 we only cited Ryan et al., 2008 why hypothesized deposition effect of particles on pipe wall due to van der Waals force.

141:2-10: Why mention that more particulate matter accumulated on the wall of the PVC pipe than the lined Fe pipe?

ANSWER: If the inclusion of this result can be justified can it also be expressed quantitatively. We need to refer to Figures 2.10 and 2.12 from Ryan et al., 2008 and from there can be stated

that at velocity 0.1 m/s particle concentration on wall will be 6-9 times better for PVC than lined Fe pipes.

141:6: Would benefit from rewording. If you want to make the point that particles don't seem to settle in distribution systems under their own weight you could reference a) the section in Boxall et al. (2001) that mentions settling velocities and/or b) the end of section 2.1 in van Thienen et al. (2011):

ANSWER: We will reword since the message which would like to say: particles will deposit on PVC better than on lined cast iron pipes. While Boxall et al. (2001) and van Thienen et al. (2011) do not compare deposition of particles on different pipe materials.

141:13: 'SIMDEUM', not 'SIDMEUM' ANSWER: Agree

141:20: Which van Thienen et al. paper? Two were published in 2011. Are you referring to Floris & van Thienen (2011)? The Floris and van Thienen paper is currently under review. Note that the densities of the particles used in the described experiment are comparable to those in real distribution systems but the diameters are far larger than is typical; the effects of turbophoresis and the Saffman and Magnus forces are likely to be far more significant in that experiment than in reality. van Thienen et al. (2011) noted that the effects of turbophoresis and the Saffman force are unlikely to be particularly significant in distribution systems and the Magnus force is even less likely to have an effect.

ANSWER: We mean this paper: van Thienen, P., Vreeburg, J. H., and Blokker, E. J.: Radial transport processes as a precursor to particle deposition in drinking water distribution systems, Water Res., 45, 1807–1817, 2011b.

141:28: Do you mean 'material accumulated within a wash-out or hydrant body' during a flush or simply material that was mobilised from along the entire pipe length during the first pipe turnover during a flush?

ANSWER: We mean all material mobilised along the entire pipe length during the first pipe turnover during a flush except material in hydrant body/standpipe.

142:2: Not sure if the term 'Cohesive Theory' has been used before in the literature. Might want to use the term 'cohesive transport model' instead as that appeared in Boxall and Saul (2005).

ANSWER: We agree, and will use 'cohesive transport model' and cite as well to Boxall and Saul (2005)

142:3: 'both the accumulation and erosion of particles have been combined' – needs rewording. Could say 'With the PODDS model discolouration material is assumed to be homogenously distributed around the pipe's circumference in cohesive layers of particulate matter. The layer strength is a function of the the maximum daily shear stress. Material erosion and regeneration processes can be modelled through calibration.'

ANSWER: We agree

142:8: 'occurs', not 'occursr' ANSWER: Agree

142:9: 'are conditioned', not 'is conditioned' ANSWER: Agree

142:9: 'the background', not 'background' ANSWER: Agree

142:11: 'the treatment', not 'treatment' ANSWER: Agree

142:14: Also worth referencing Vreeburg et al. (2008) ANSWER: Agree

142:28: A very good point! ANSWER: Thanks

142:29: 't-piece', not 't-bend' ANSWER: Agree

143:3: 'spikes', not 'pikes' ANSWER: Agree

143:3: 'corresponded' a better choice of word than 'fitted' ANSWER: Agree

143:8: PODDS model emphasizes relationship between applied (flushing) shear stress (a function of more than just bulk velocity) and the rate of change of a) turbidity potential and b) supply of material to the bulk water. It might therefore be appropriate to work with shear stresses rather than velocities in this paper if an objective is to extend the PODDS model.

ANSWER: We considered shear stresses, considering diameter of pipe as well

143:9: 'online measurement timesheet' - needs rewording

ANSWER: It is meant measurement protocol, during filed works

143:19: Oxidation using air? Not chlorine, ozone or UV?

ANSWER: For the supply of the drinking water network, the treatment with oxidation using air 700 m³/day –1 has been applied. Yes, oxidation using only air, partly chlorination.

143:19: 700m³/day could be better expressed as a setpoint concentration.

ANSWER: Total average daily demand for a city

143:24: Vreeburg et al. (2008) found that filter backwashing correlated with turbidity spikes.

ANSWER: In the time of backwashing one-way valve is closed, so backwashing, before in our case valves worked with wrong algorithm

145:3: Demand figure seems low: in the UK hydraulic modellers typically estimate the per-capita consumption to be 140L/person/day, which would give a total of 1260m³/day for 9000 inhabitants.

ANSWER: In our case, data is real consumption from flow meter

145:5: 'There were two', not 'there where two'

ANSWER: Accepted and updated

145:25: Equation incorrect (check the units). Should be $L=Q/A * t$, not $L=A/Q * t$

ANSWER: Accepted and updated

146:7: 'spike', not 'pike'

ANSWER: Accepted and updated

146:8: Mean or median?

ANSWER: corrected, its average smallest value just before spike starts, it describes turbidity in straight section, corrected to NTU_f

146:5: Need to state that this was done for every flushed pipe section. Would be clearer if "(30 NTU and 26 NTU)" and "(Fig. 4)" were combined e.g. "For example, the locations in the network corresponding to the spikes of 30NTU and 26NTU in Fig. 4 were found using Eq. 1 and an estimate of flow".

ANSWER: Thanks for Your advice, corrected

146:10: It is not clear whether $>1 J$ coefficient is found for profiles containing >1 sharp turbidity spike.

ANSWER: These are special cases, where topology is specified

146:10: If there are no fittings along a pipe length then the peak turbidity curve corresponds to the turnover time (logarithmic rise up to the turnover time then exponential decay afterwards). It should be noted that this peak needs to be distinguished from spikes

corresponding to material mobilised from fittings and fixtures. This could be done either visually or using the turnover time.

ANSWER: Agree and updated.

146:13-15: Needs rephrasing. Why is lots of data required?

ANSWER: As many data as possible is needed, to create a database for several situations, according theoretical mass-balance from treatment station.

146:20: Remove 'it means that'

ANSWER: Accepted and updated

146: 23: More common to use S_0 (hydraulic gradient) than ΔH (headloss over length of pipe) in this equation

ANSWER: the correct formula is $\tau = \rho \cdot g \cdot D/4 \cdot I$ with the hydraulic radius $D/4$ in metres and the dimensionless energy gradient I . This energy gradient is $I = h_f / L$ with the head loss h_f in metres as well as the pipe length L . The head loss is calculated with the Darcy-Weisbach equation $h_f = f \cdot L/D \cdot v^2 / (2 \cdot g)$. Agree that should be used term energy gradient (I) and maximum shear stress in N/m^2

146:24: Shear stress typically expressed in Pa or Nm^{-2} (equivalent units).

ANSWER: Accepted and updated

147:5: Remove 'wetted': should only be used as a prefix to 'perimeter'.

ANSWER: Accepted and updated, thanks for advice

147:8-10: The use of C is confusing: C is used in the PODDS model to represent turbidity potential i.e. the amount of material bound to the pipe wall, not the turbidity of the bulk water.

ANSWER: According to correlations turbidity is calculated to potential amount of material (dry mass) on pipe wall

147:10-16: The use of R is confusing: R is used in the PODDS model to represent the rate of material supply from the pipe wall to the bulk water when the applied (flushing) shear stress exceeds the material layer strength. $R = P(\tau_a - \tau_c)^n$. The units of R are $NTUm \cdot s^{-1}$.

ANSWER: Formula is updated

$$\Delta C_c(t=1) = P(\tau_a - \tau_c)^n \cdot 2\pi r L \quad (3a)$$

where P =gradient term [NTU/m²]

n =power term [-]

τ_a =applied shear stress [N/m²]

τ_s =current layer strength [N/m²]

r =radius of pipe [m]

L =length of link [m]

147:15: The use of n is confusing: n is used in the PODDS model as described above.

ANSWER: Corrected to nt , its mean time step

147:16: The definition /equation for $Turb_total$ should feature in a separate sentence. With the PODDS model the amount of material mobilised per flush is typically quantified by integrating NTU w.r.t time then multiplying by flushign flow (assuming that is constant) to give a value in unist of $NTUm^3$.

ANSWER: $Turbidity_total$ is integrated from NTU units in turbidity curve from flushing event.

147:20: This expression typically features a denominator of flow.

ANSWER: Thanks, in this case we used it to predict erosion of layer by rised shear stress.

148:3: C should appear after 'turbidity peak' to make the sentence read better. Ideally a different letter should be used to represent turbidity peak. The peak will occur at the turnover time (L/V) if no material is mobilised from fittings).

ANSWER: Turbidity peak for plug flow will occur at some (current) time C , after which it will gradually decrease, described by turbidity decrease term.

148:3: Why consider maximum hourly velocities? I don't understand this sentence.

ANSWER: The maximum peak value was calculated from the difference of the standard maximum velocities (hourly and flushing), in terms of corresponding shear stresses, regardless to the mass accumulated in pipe.

148:8: Where does the gradient and offset terms in this expression come from? If it has been derived using empirical data where is the data and the R^2 value? Why is only one formula

presented? If the flushing shear stress, pipe material and diameter differed between flushes then this relationship will be vary between flushes.

ANSWER: The gradient and offset terms is taken from linear corelation curve

148:11: Confusing: the maximum turbidity value(s) per flush can be determined from the turbidity curves alone.

ANSWER: The magnitude of decrease depends on the coefficient used: P and exponent: n (variables in our case P = 0.1 and n = 0.5) in the rate of supply from the layer calculations.

148:11: 'rate' is a better word than 'magnitude'

ANSWER: Accepted and updated

148:13: Did you investigate whether P and n could/should vary between flushed pipes?

ANSWER: It should, depend from pipe material and age, so changeslayer strength, coefficient n and ascent of turbidity curve

148:18: 'constant flushing flow' and 'constant flushing shear stress'.

ANSWER: Corrected

148:22-23: Can this statement be quantified statistically e.g. "67% of 45 anomalous turbidity spikes could be attributed to material mobilisation from t-pieces and 23% could be attributed to 90 degree bends".

ANSWER: No, more data is required, this is only from our field experiments.

149:4: NTU_averge: average spelled incorrectly. Term not used above

ANSWER: Accepted and updated

149:6: Confused: shear strength does not have units of NTU m^3

ANSWER: Its meant amount of mass from potential stored layer

149:8: Better expressed as an integral w.r.t t. Units problem: the units of the expression are NTU kg ?

ANSWER: Dry mass of sediments

149:9: Was the mass of mobilised material calculated so as to include all mobilized material or only the material mobilised from fixtures and fittings?

ANSWER: Mass of mobilised material calculated so as to include all mobilised material

149:17: Assumption has previously been stated.

ANSWER: Yes, that's correct

150:2: Were the pipes flushed at night to minimise the error in your flow estimates?

ANSWER: Yes, and also not to disturb traffic.

150:12-19: It is difficult for the reader to compare kg and g/m⁻¹. The values should be converted to common units.

ANSWER: There is calculated total theoretical mass in junction, depending to turbidity curve, it could also be expressed as 50 to 290 g of loose deposits in various junctions.

150:12-13: Why were the values so much higher than others in the literature (which take into consideration not only the material mobilised from fittings but also from the pipe wall too)? Are you suggesting that much more material accumulated in fittings

than along the pipe wall?

ANSWER: We have situation, that our networks has much more accumulated sediments than in other places, which has been investigated. Yes we proofed that amount of material in fittings is much more higher than along of pipe in stright sections. Still we believe, that proportion of coeficient in fittings could be similar in other networks with lower amount of loose deposits.

150:19: See also (Vreeburg, 2007, pp.51–52)

150:19: 'flushing shear' ANSWER: Accepted and updated

150:19-21: How did you test for correlation? Would it make more sense to look at the relationship between the amount of material that was mobilised per fitting and the difference between the maximum daily shear stress and the flushing shear stress?

ANSWER: We tried, but in several cases, for example further from water treatment plant in similar shear stresses and circumstances, amount of material varies much.

150:27-151:15: This appears to be an extension to the literature review. What does this section contribute to the discussion section?

ANSWER This is discussion about previous investigations in this field of science.

151:9-15: Blokker et al think that rate of material accumulation is related to the maximum daily velocity; Boxall et al think that the maximum amount of material that can accumulate and the strength of that material is not a function of maximum daily velocity but maximum daily shear stress. Shear stress is itself a function of not just velocity but also diameter and roughness.

ANSWER We considered maximum daily shear stress

151:16-19: Repeated; already included in section 2.5

ANSWER Accepted and deleted

152:8-11: As previously stated the Magnus and Saffman forces have limited effects in most drinking water distribution systems. Also, neither explain how material remains attached to the wall.

ANSWER Magnus and Saffman force shows particle movement in the system depending of pipe diameter and flow velocity, till it deposits. Deposition to the walls is more linked to cohesive forces.

153:8-13: Could get very different model fit if assume that the first two data points are just outliers. Higher temporal data resolution could have helped here. How did you decide how frequently to sample turbidity? In your method section it said dt varied between 5s to 1min.

ANSWER For turbidity measurements we used Hach SC100 online turbidity meter with logger interval 5s -1min (1min in first field experiments), also to verify information in same time, we measured turbidity with manual turbidity meter in time step 1min.

153:18-24: Measure of model fit to data should be quantified.

ANSWER Agree

153:27: 'Non-Disclosure Agreement' not 'copyright law'

ANSWER Agree, corrected

154:2: Aisopou spelled incorrectly

ANSWER Agree, corrected

154:5-6: Yes, these parameters are not constants.

ANSWER By using the parameter values from Asopou et al. (2010) and Naser (2006) in our case studies, the modeled results differed significantly. These results indicate that the parameters are site specific and therefore cannot be generalized.

155: Units confusingly differ from those used in PODDS-related papers (tau, R, P, C)

ANSWER Thanks for comment, units are corrected

166: What is 'J junct'?

ANSWER Corrected

170: No pipe of this length is listed in Table 3

ANSWER In this table are summarized study cases with only with T-pieces

References

Boxall, J., Skipworth, P. & Saul, A., 2001. A novel approach to modelling sediment movement in distribution mains based on particle characteristics. In *Water Software Systems: v. 1: Theory and Applications*. CCWI2001.

Floris, R. & van Thienen, P., 2011. Experimental investigation of turbulent particle radial transport processes in DWDS using optical tomography. *Drinking Water Engineering and Science Discussions*, 4(1), pp.61–83.

van Thienen, P., Vreeburg, J.H.G. & Blokker, E.J.M., 2011. Radial transport processes as a precursor to particle deposition in drinking water distribution systems. *Water Research*, 45, pp.1807–1817.

Vreeburg, J.H.G., 2007. *Discolouration in Drinking Water Systems: A Particular Approach*. PhD thesis. Netherlands: Delft University of Technology.

Vreeburg, J.H.G. et al., 2008. Impact of particles on sediment accumulation in a drinking water distribution system. *Water Research*, 42(16), pp.4233–4242.

A flow chart for second coment

$$\text{Turbidity}(t \geq 2) = \text{Turb}_{\max}(t=1) \times \left(1 - \frac{R \times t}{\text{Turb}_{\text{total}}}\right) + \text{Turb}_{\text{average}} \times \underbrace{\left(1 - \frac{R \times t}{(Q \times t \times \text{Turb} \times \text{TSS} \times 10^{-6})}\right)}_{\text{Additional term describing the impact of a fitting}} \quad (6)$$

Determ variables of turbidity eq., considered by maximal daily shear stress and following maximal potential of stored sediment layer in pipe

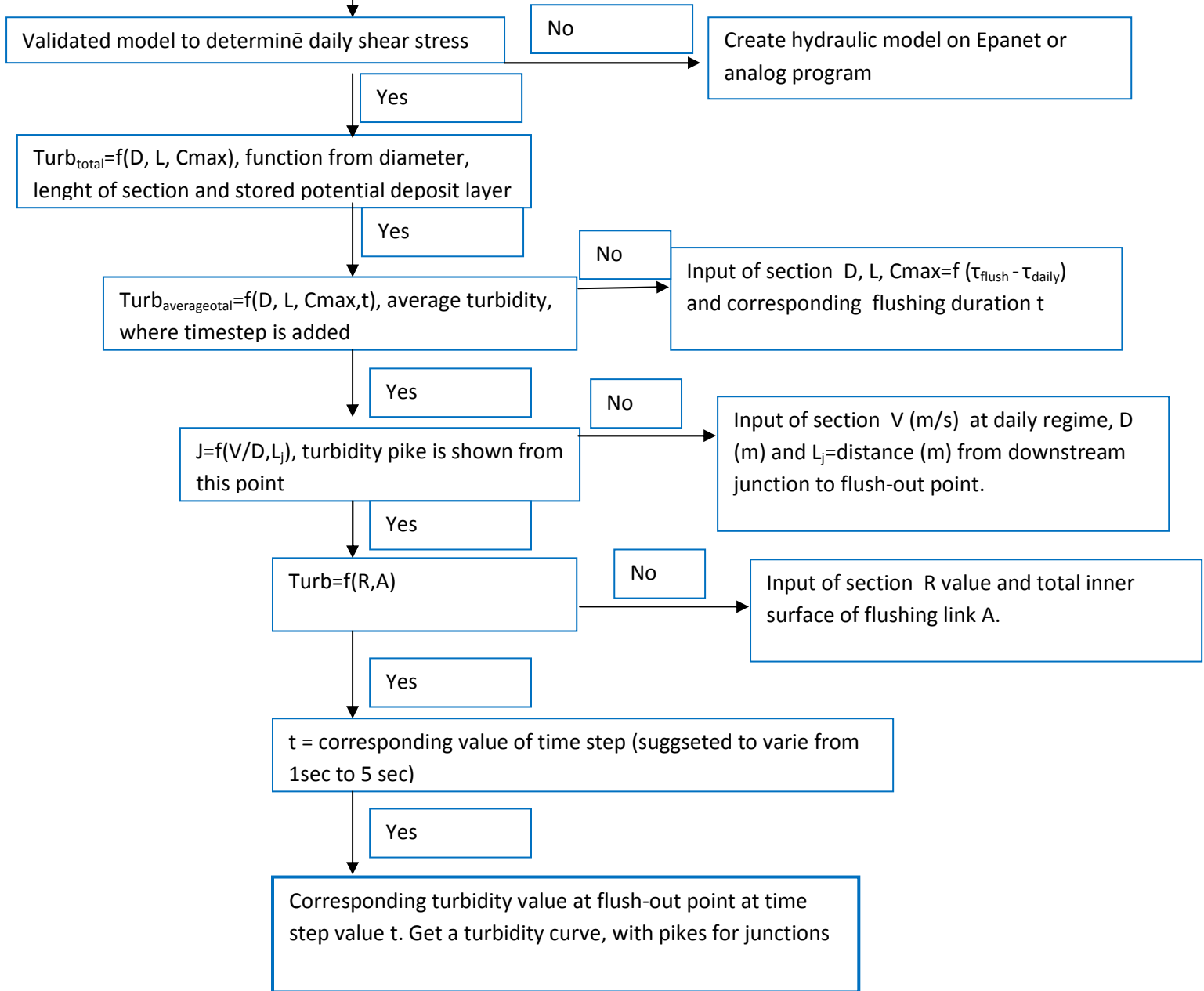

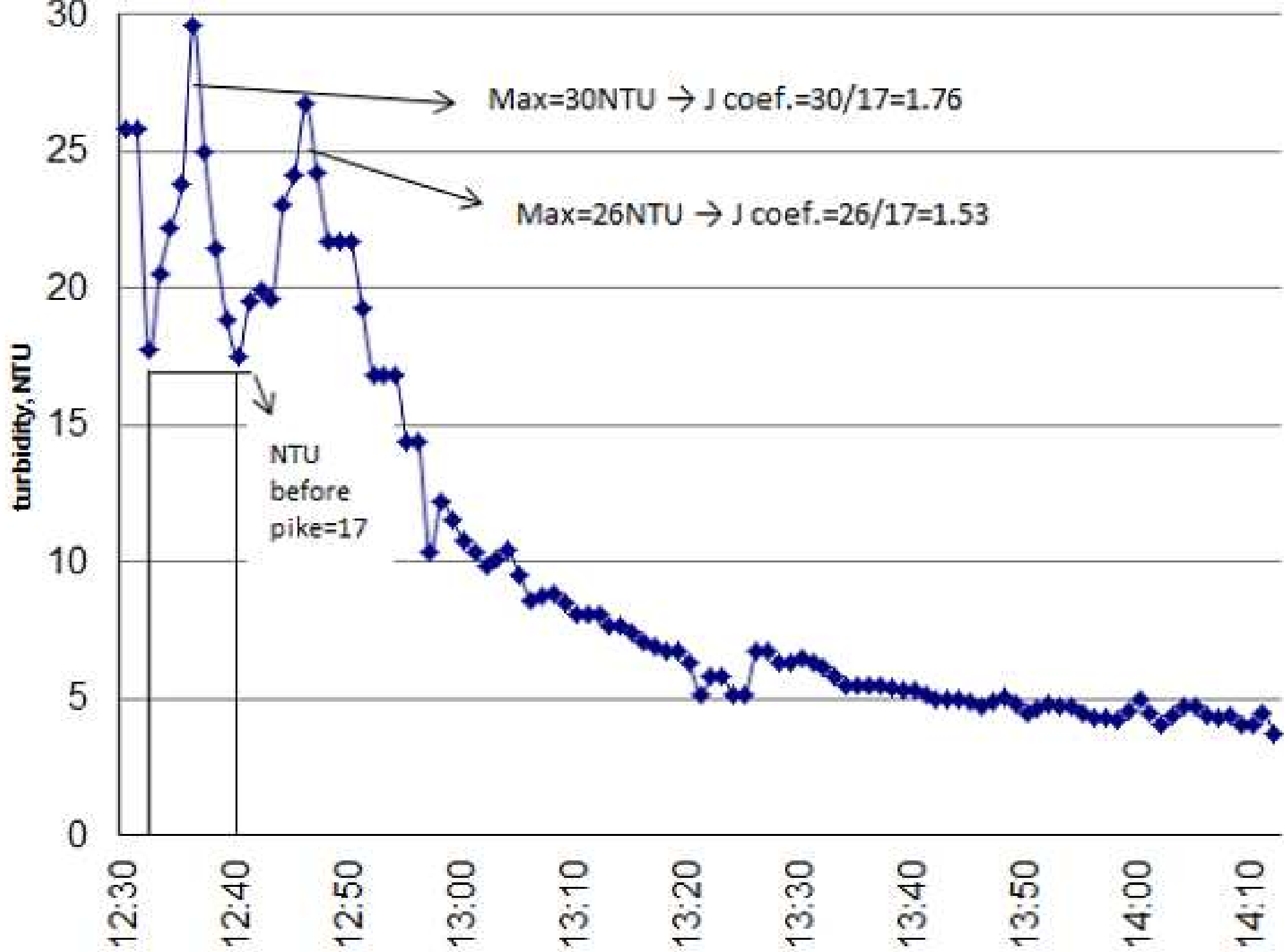

ANSWERS TO A REFEREE #1 COMMENT ABOUT CASE STUDY
EXAMPLES

Here some of the case studies about how J values are calculated

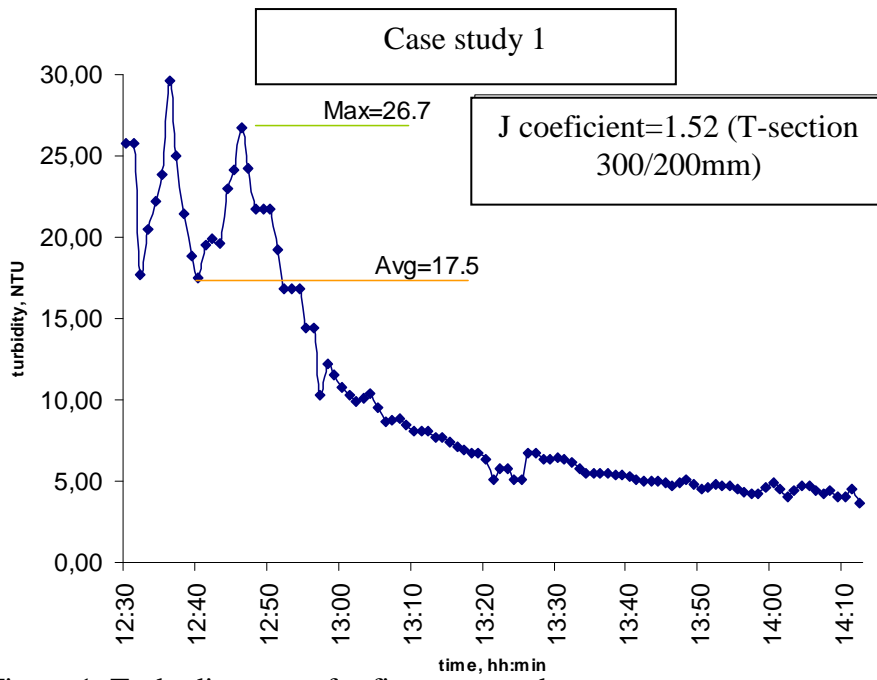

Figure 1. Turbidity curve for first case study

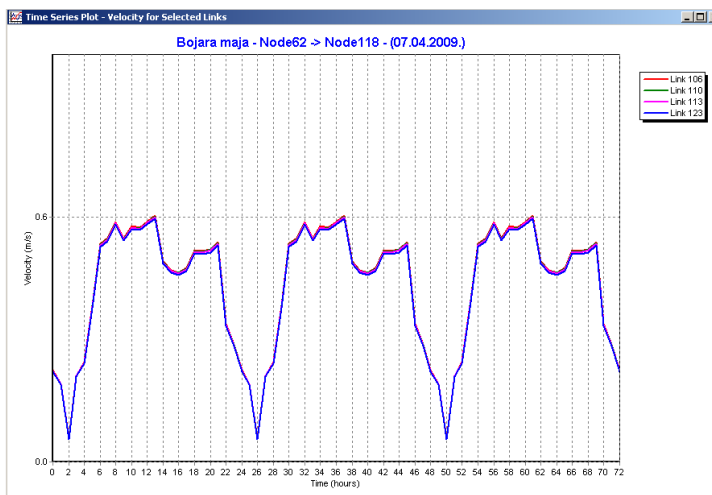

Figure 2. Daily velocity for section from case study 1

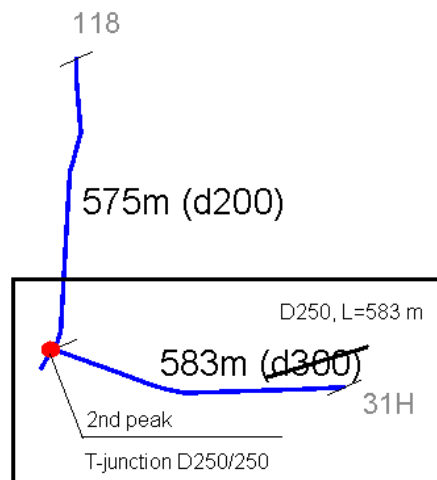

Figure 3. Topology for case study 1

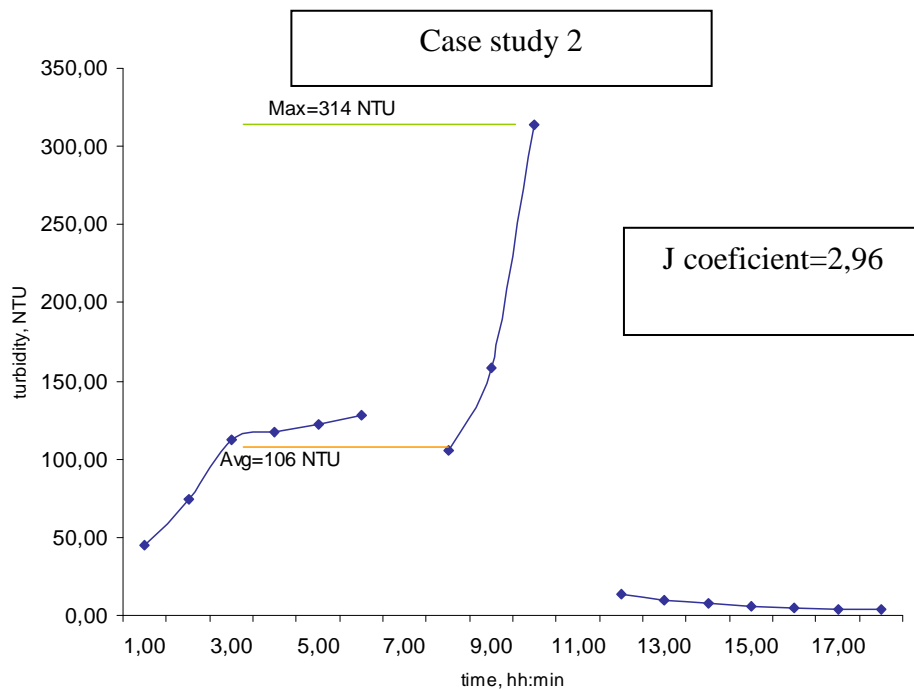

Figure 4. Turbidity curve for case study 2

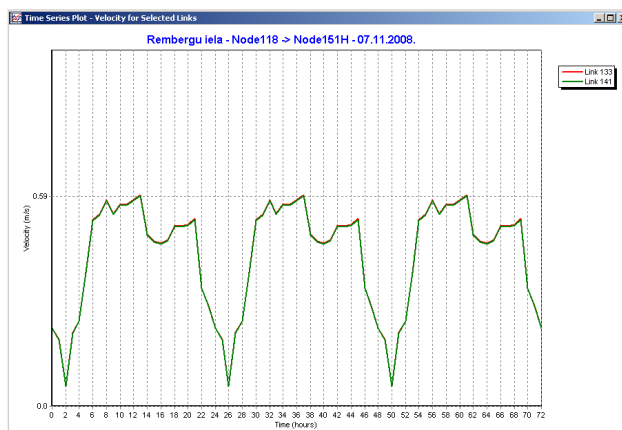

Figure 5. Daily velocity for section from case study 2

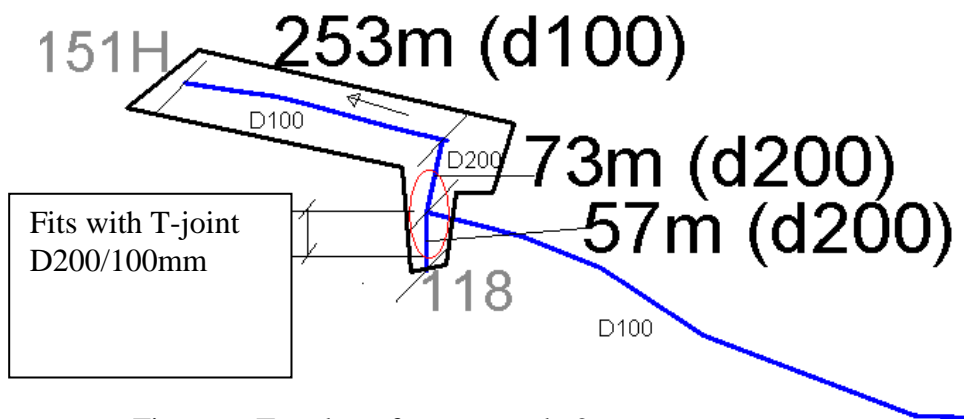

Figure 6. Topology for case study 2

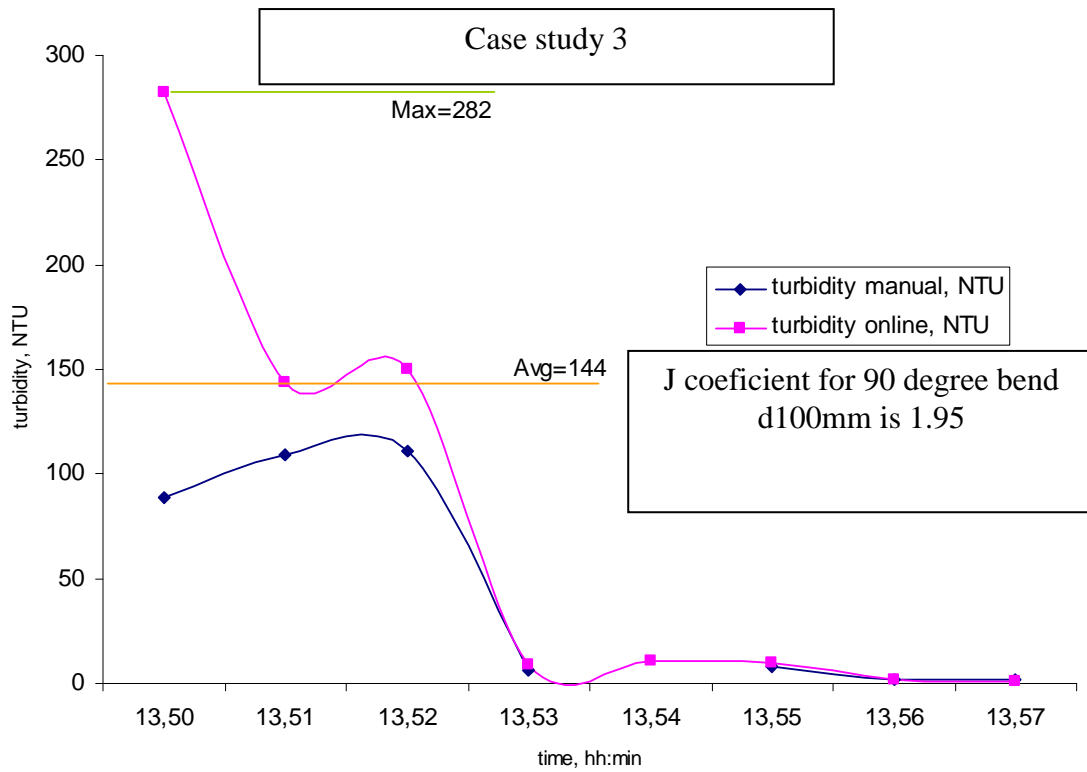

Figure 7. Turbidity curve for case study 3

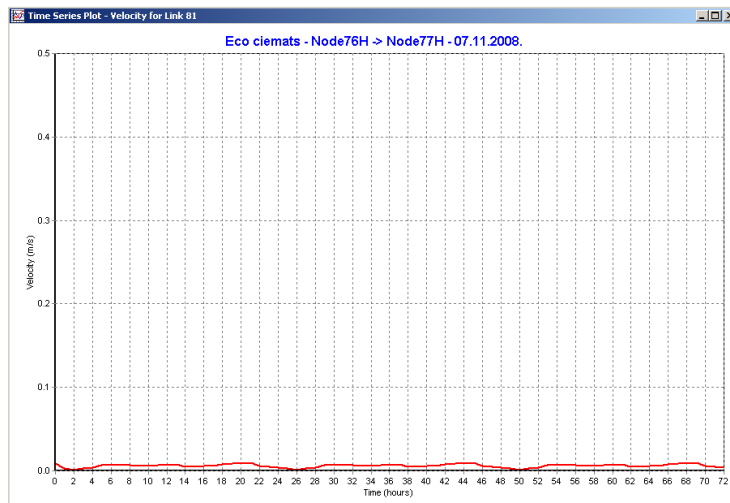

Figure 8. Daily velocity for section from case study 3

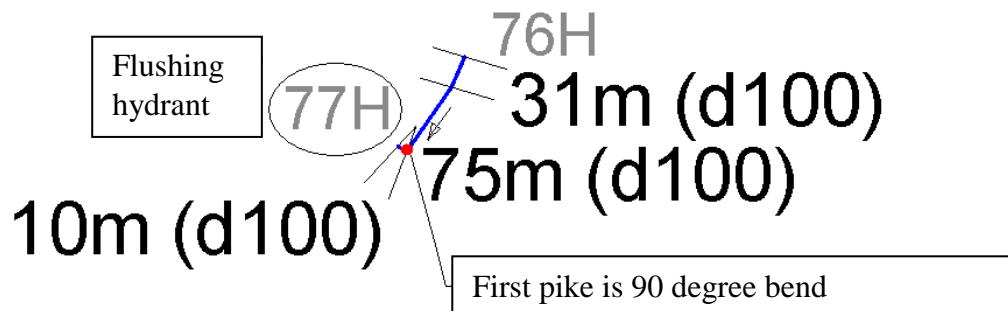

Figure 9. Topology for case study 3

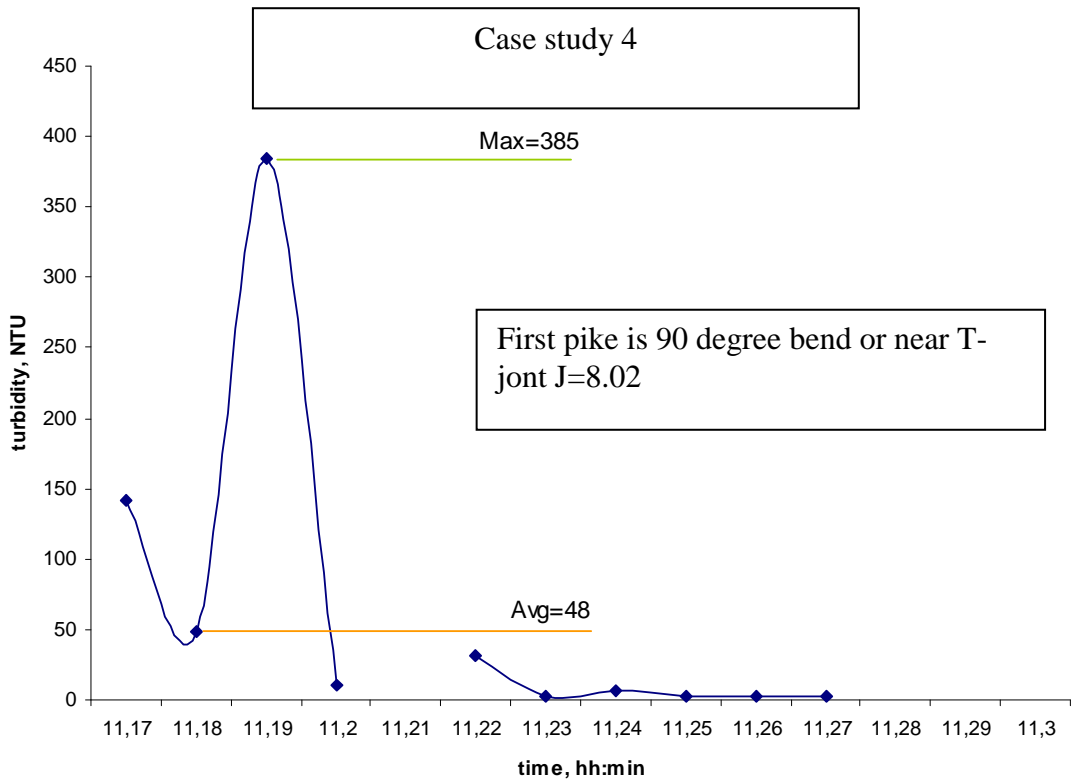

Figure 10. Turbidity curve for case study 3

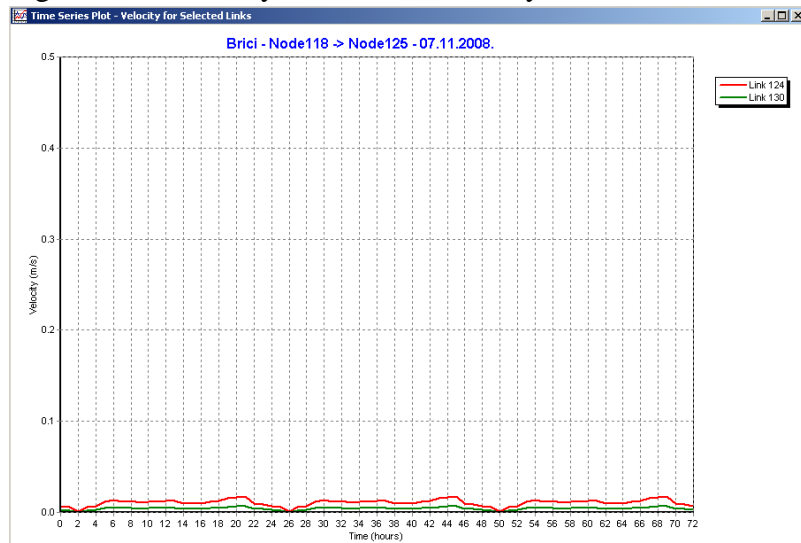
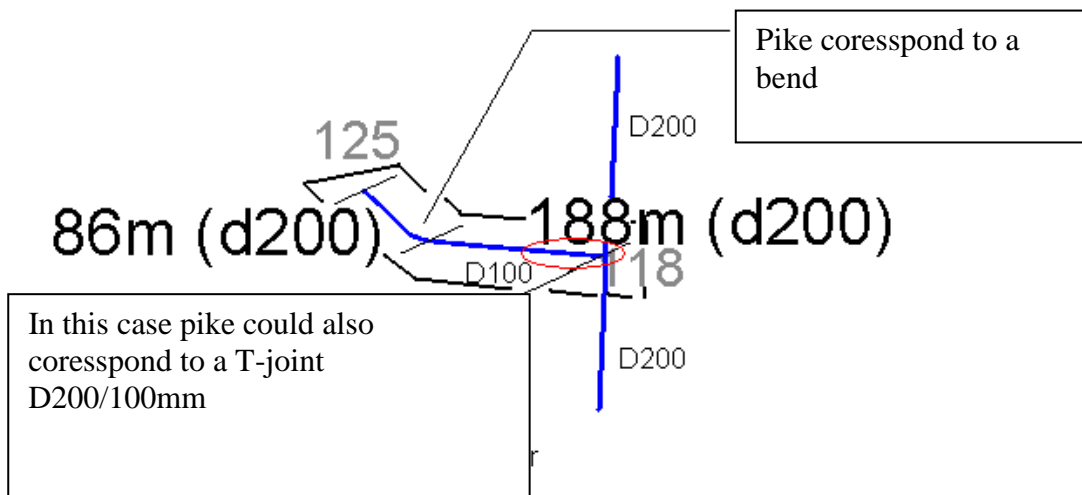

Figure 11. Daily velocity for section from case study 4



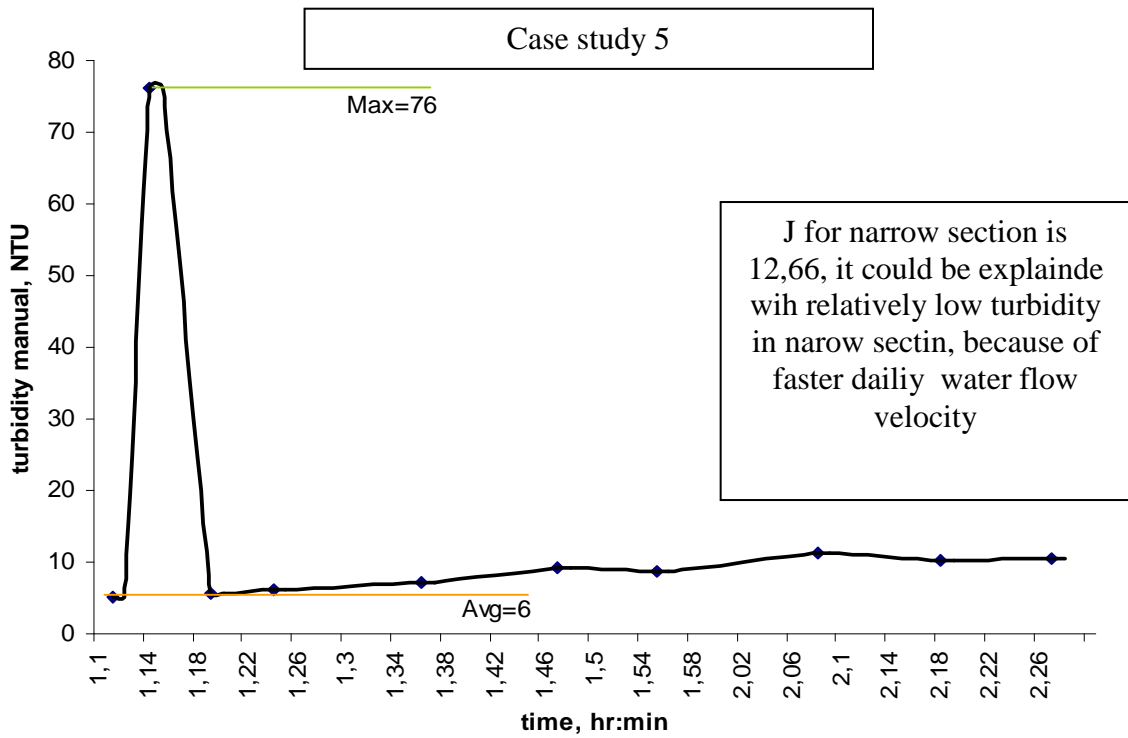

Figure 12. Turbidity curve for case study 5

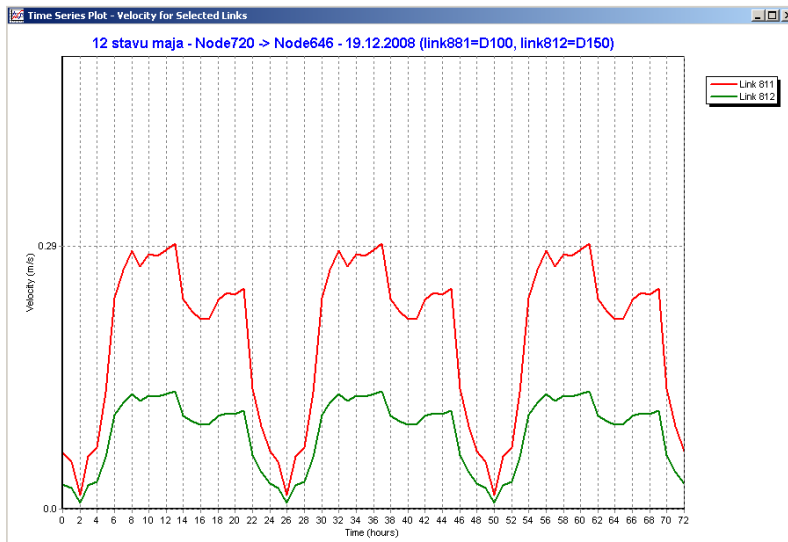

Figure 13. Daily velocity for section from case study 5 (d150 and d100mm)

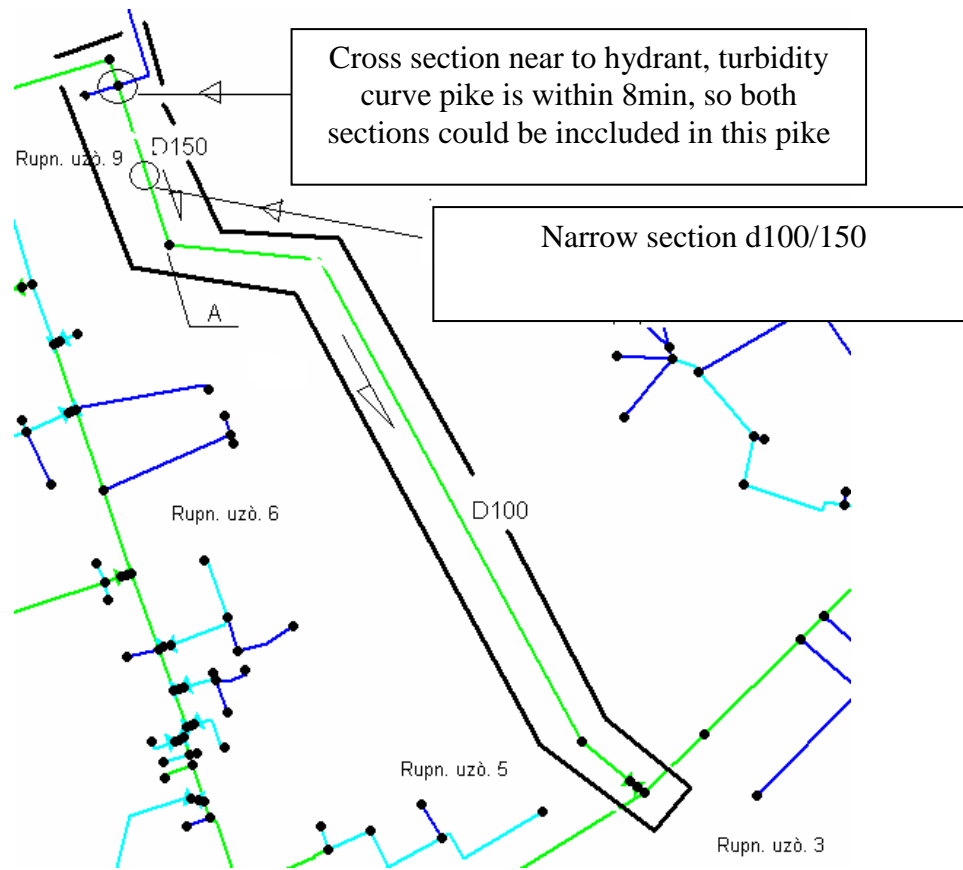

Figure 14. Topology for case study 5

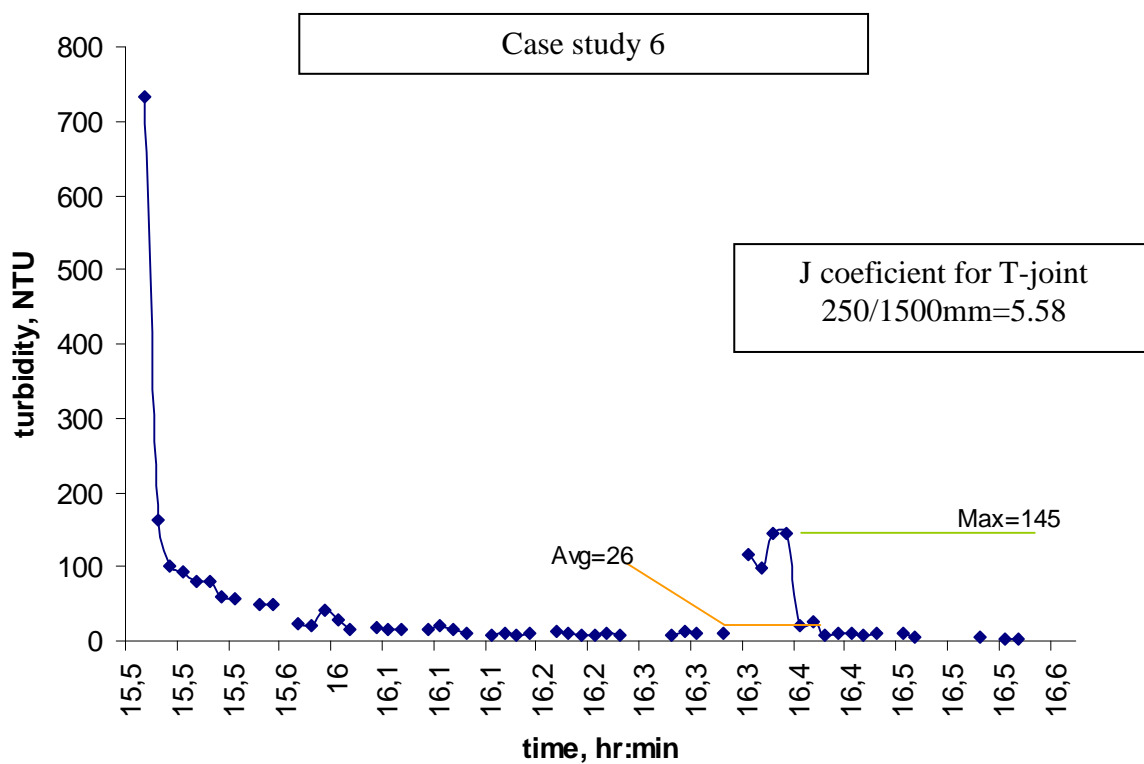

Figure 15. Turbidity curve for case study 6

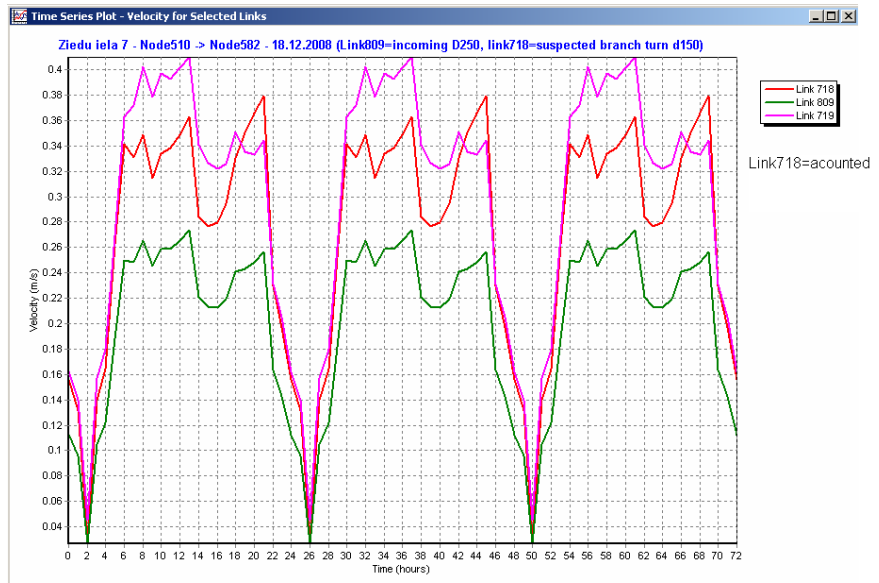

Figure 16. Daily velocity for section from case study 6

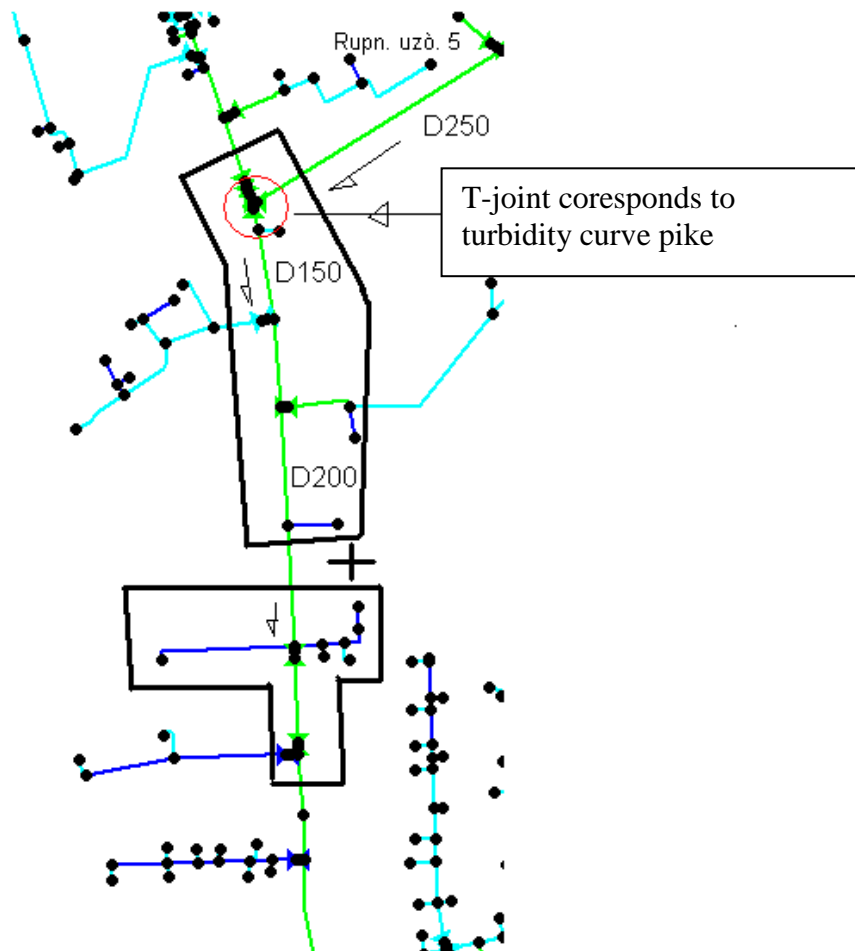

Figure 17. Topology for case study 6

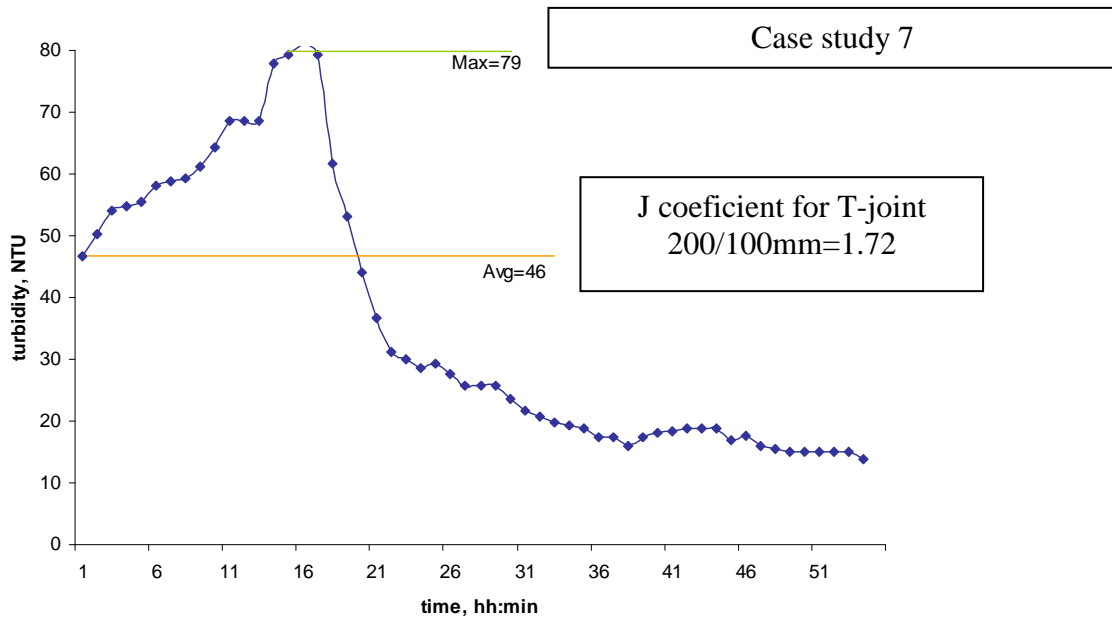

Figure 18. Turbidity curve for case study 7

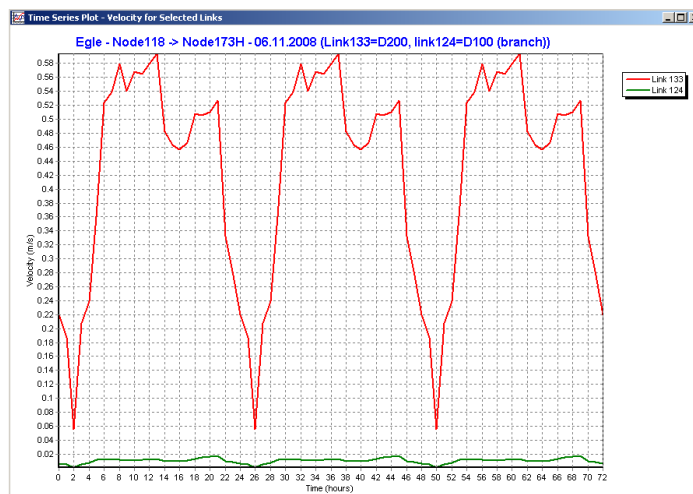

Figure 19. Daily velocity for section from case study 7

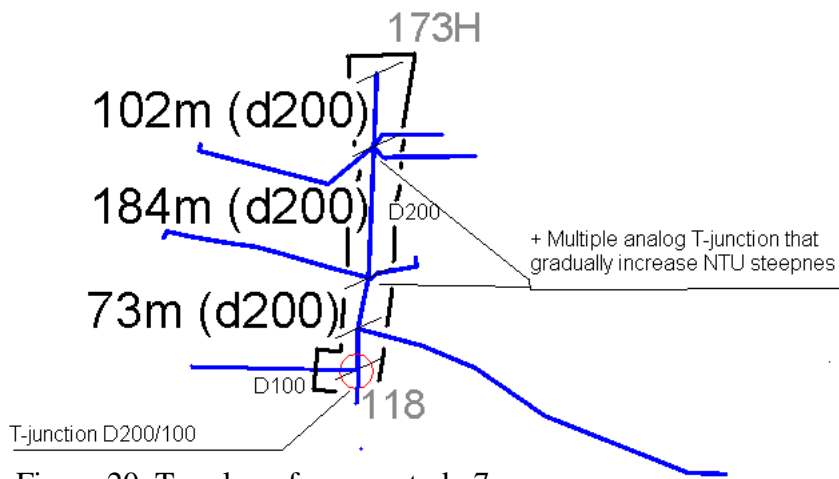

Figure 20. Topology for case study 7

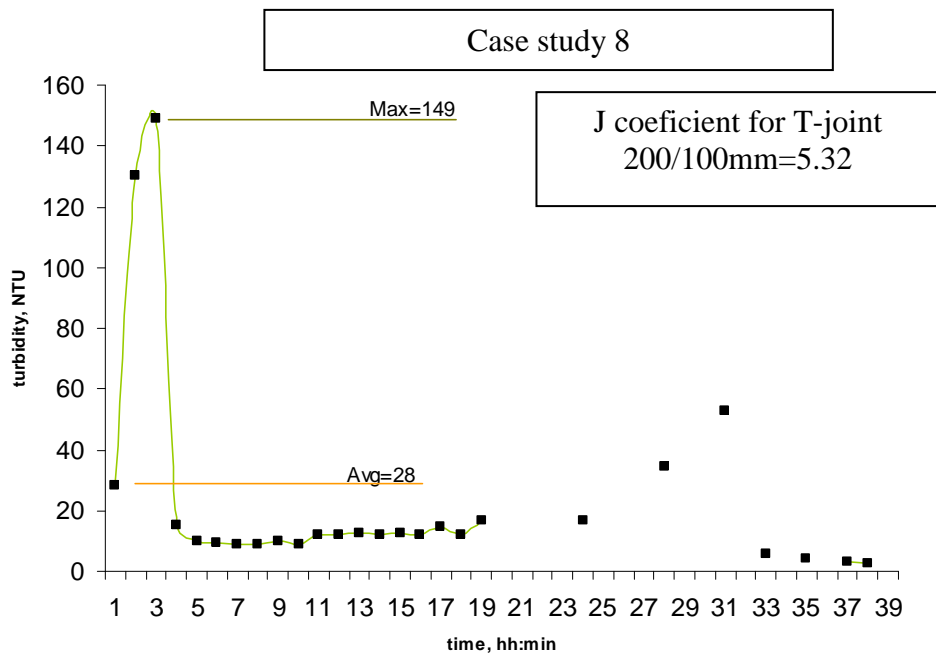

Figure 21. Turbidity curve for case study 8

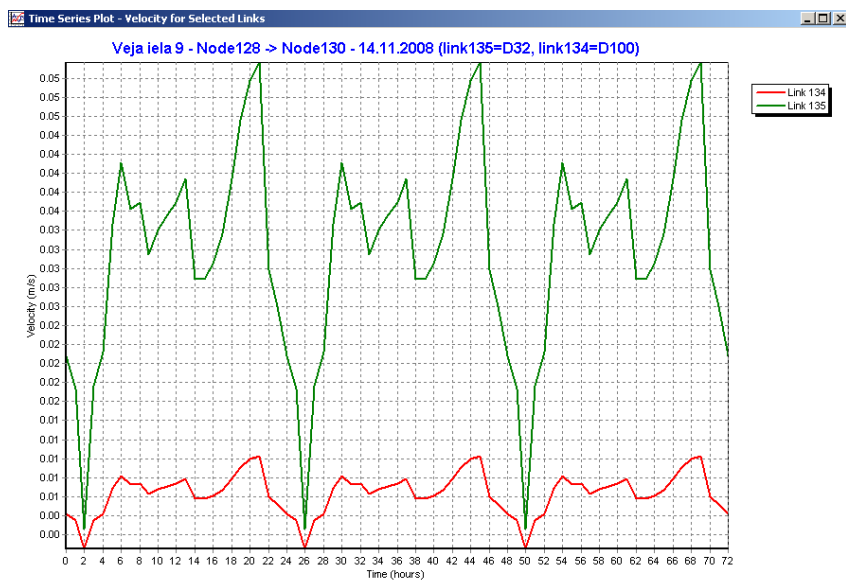

Figure 22. Daily velocity for section from case study 8

